

# GTD GT45

GEOTHERMAL & WATER WELL DRILL RIG



## GTD GT45 DRILL RIG

The **GT series** of drill rigs are known for their **high productivity** and **reliability** in geothermal drilling, with **proven performance** in both domestic and commercial applications around the world. These rigs are the **number one choice** for **leading industry professionals**, thanks to their **versatility** and ability to handle a variety of drilling conditions with **precision** and **efficiency**.

The **GT45** model is designed to reach **depths beyond 2,300 feet (700 meters)** using **mud, air, and hammer** drilling methods. It is equipped with our unique **rod rack and loading system**, which is the most **robust, reliable,** and **safest rod handling system** on the market, ensuring **maximum safety** and **efficiency** in all drilling operations.

### DIMENSIONS & WEIGHT

- ▶ Length 38' 7" (11.8m)
- ▶ Width 7' 8" (2.4m)
- ▶ Height 10' 5" (3.2m)
- ▶ Weight 44,000 lbs - 55,000 lbs (20,000 kg - 25,000 kg)  
Actual weight will vary depending on the options selected and installed, e.g. Rods...

### DERRICK & FEED SYSTEM

- ▶ 46,300 lbs (21,000 kg) pull-back
- ▶ 17,640 lbs (8,000 kg) push-down
- ▶ 24' 7" (7.5 m) top head stroke

### DRILL PIPE & CASING

- ▶ 3½" (88.9 mm) x 20' (6 m)
- ▶ 40 rod capacity - 800' (240 m)
- ▶ Max diameter 12½" (320 mm)

### ENGINE

- ▶ Doosan DL08 Tier 4 (Stage 5)
- ▶ 290 hp (213 kW)
- ▶ Typical engine speed - 1400 rpm - 1600 rpm
- ▶ Max engine speed - 1800 rpm

### ROTARY DRILL HEAD

- ▶ Variable twin Eaton motor head with 2" (60 mm) thru-hole
- ▶ 0-135 rpm @ 6195 lb-ft
- ▶ 0-260 rpm @ 3097 lb-ft

### CRAWLER (TRACK) BASE

- ▶ Doosan Solar 130
- ▶ Steel with rubber pads
- ▶ Wireless remote travel

### GTD STANDARD FEATURES

- ▶ Sideshift - Sliding Drill Head
- ▶ Swivel & Floating Spindle Sub
- ▶ Height adjustable working table
- ▶ Double Clamps - One rotating
- ▶ Hydraulic Centralizing Rollers
- ▶ Hydraulic Breakout Chain Wrench
- ▶ Auxiliary Hydraulic Ports and Controls
- ▶ Main Winch - 11,000 lbs (5,000 kg)
- ▶ Wire/Sandline Winch
- ▶ Water Injection Mist Pump
- ▶ DTH Lube System
- ▶ Rod Rack & Rod Loader
- ▶ Hydraulic Welder & Generator (7.5 kW)
- ▶ Self Loading Jacks/ Outriggers
- ▶ Air Compressor: 24 cfm (673 lpm), 130 psi (9 bar)
- ▶ Centrifugal Pump: 4x3x13 Single-stage
- ▶ 5x6 Triplex Piston Pump: 317 gpm @ 580psi (1200 lpm @ 40 bar)

### OPTIONS

- Hydraulic Sliding Rod Wrench
- Triple Clamps
- Sandline Winch Length 1,000' - 6,500' (300 m - 2,000 m)
- Angled Drilling
- Safety Cage

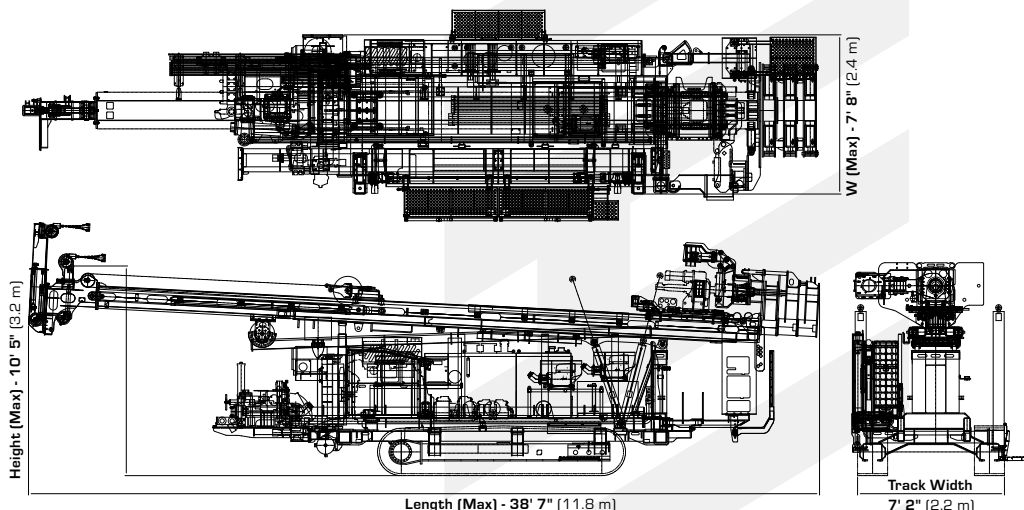



## GTD GT45 DRILL RIG

**ROD LOADER**



**ROD RACK SYSTEM**



**OPERATED BY THE LEAD DRILLER, SECOND MAN OR BOTH ON DUAL CONTROLS**



**HEIGHT ADJUSTABLE WORKING TABLE**



**CAN BE USED AS A CASING EXTRACTOR**



**SLIDING HEAD**



**ADJUSTABLE HIGH / LOW ROTATION & TORQUE**



**TRIPLE CLAMPS  
1 ROTATING & 2 FIXED  
12 1/2" (320 mm) OPENING**



**HYDRAULIC CHAIN WRENCH**



**HYDRAULIC CENTRALIZING ROLLERS**



**HYDRAULIC SLIDING ROD WRENCH**



**STEEL TRACKS WITH RUBBER PADS**



**REMOTE CONTROL**



**SELF LOADING**



**ANGLED DRILLING**



**4 x HYDRAULIC LEGS TO LIFT & LEVEL THE RIG**



## GTD GT45 DRILL RIG

**COMPRESSOR**

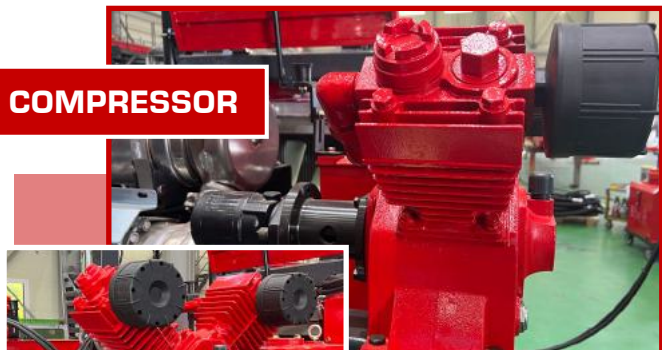

USEFUL FOR PNEUMATIC TOOLS,  
PRIMING CENTRIFUGAL PUMPS,  
CLEARING HOSES/PUMPS, ETC.  
(PREVENTS COLD WEATHER OVER NIGHT FREEZING)

**INDEPENDENT  
MAIN WINCH &  
WIRE/SANDLINE  
WINCH**



**ROTATING 90°  
AND EXTENDS**

**AUXILIARY HYDRAULICS**



USEFUL FOR POWERING  
SAND GUZZLERS, GROUTERS,  
LOOP REELERS ETC.

**WELDER &  
GENERATOR**



**SAFETY CAGE**

(OPTIONS AVAILABLE)



**TRIPLEX MIST PUMP  
FOR AIR DRILLING &  
PRESSURE WASHER**

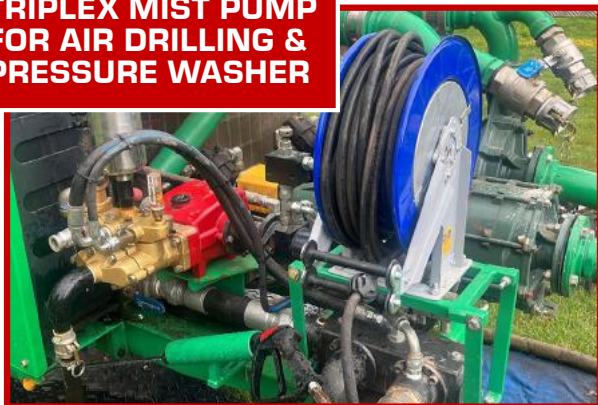

**...4x3x11 CENTRIFUGAL  
4x3x13 CENTRIFUGAL**



**CONFIGURED FOR  
DUAL MUD PUMPS  
OF YOUR CHOICE...**

**...HIGH PRESSURE  
PISTON PUMP**



**SINGLE OR MULTI STAGE  
CONFIGURATIONS**

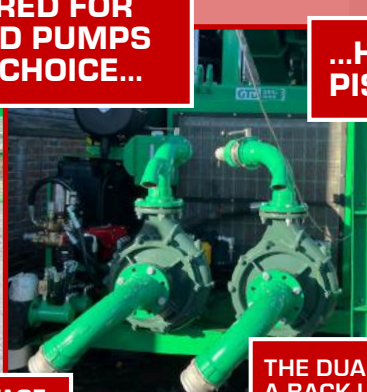

**THE DUAL PUMP SETUP PROVIDES  
A BACK-UP AND VERSATILITY IN  
CHANGING DRILLING CONDITIONS**



**GTD GT45 DRILL RIG**

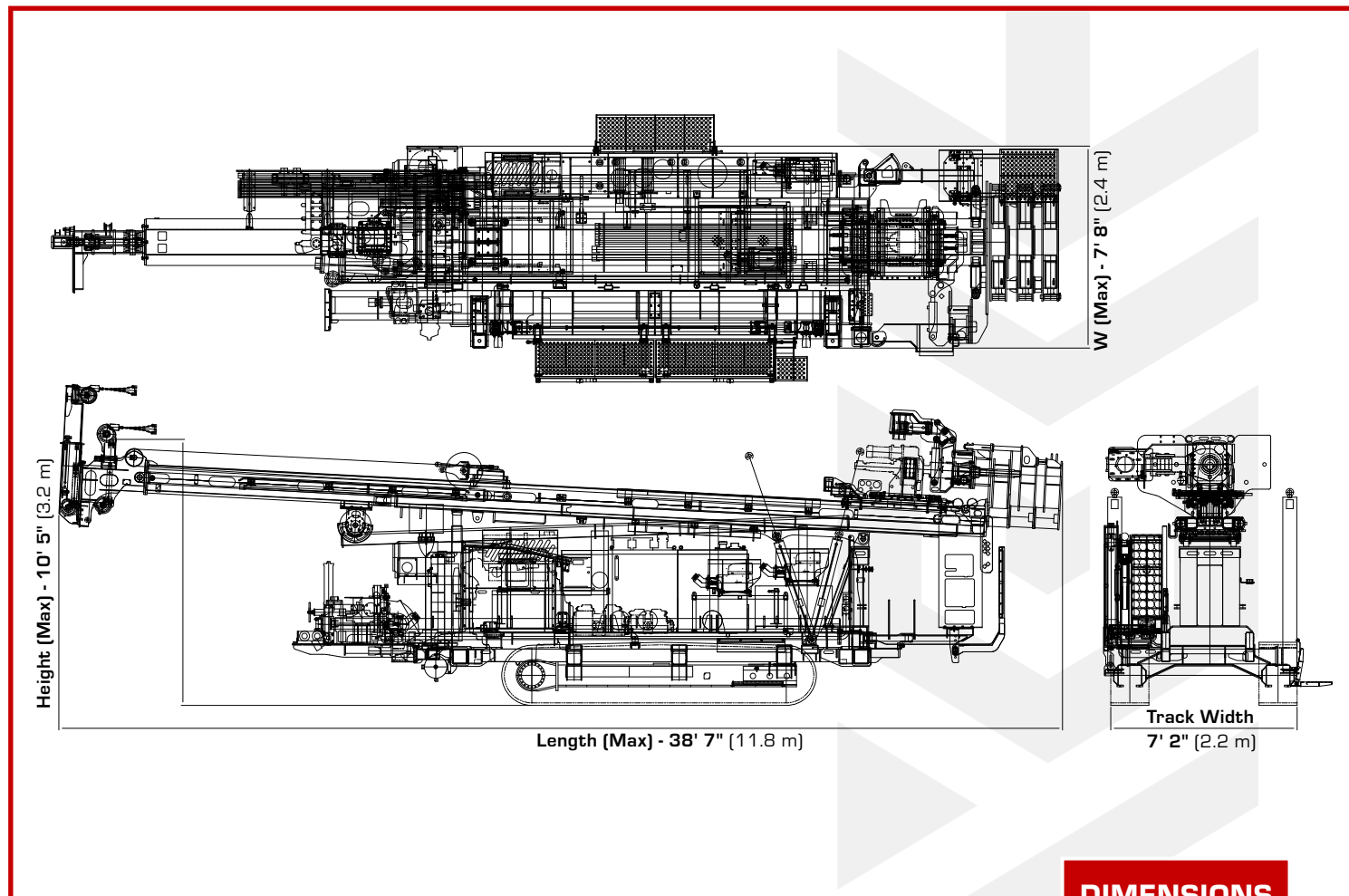

**DIMENSIONS**

NOTE: THE MEASUREMENTS ABOVE ARE THE BASE DIMENSIONS WHICH MAY BE SUBJECT TO VARIATION DEPENDENT ON FINAL DESIGN SPECIFICATIONS.

SCAN TO WATCH A GTD RIG BREAKING RECORDS



**574** FT  
[175M]  
**BOREHOLE  
DRILLED  
IN 54 MINS**

**\* DON'T BASE YOUR  
DECISION ON SPECS  
ALONE, COME & SEE  
THE RIG IN ACTION...**

**GET IN TOUCH AT  
INFO@GTD-DESCO.COM**



**13,550** FT  
[4,130M]  
DRILLED, LOOPS INSTALLED & GROUTED  
**IN ONE WEEK  
WITH ONE RIG**

SCAN TO WATCH AN INTERNATIONAL GTD CUSTOMER BREAKING RECORDS IN HOLLAND